



UNDERSTAND

- 12. Generalize** Explain how addition and subtraction of rational expressions is similar to and different from addition and subtraction of rational numbers.
- 13. Error Analysis** Describe and correct the error a student made in adding the rational expressions.

$$\begin{aligned} \frac{1}{x^2 + 3x + 2} + \frac{x^2 + 4x}{4x + 8} &= \frac{1}{(x + 1)(x + 2)} + \frac{x(x + 4)}{4(x + 2)} \\ &= \frac{4}{4(x + 1)(x + 2)} + \frac{x(x + 4)}{4(x + 1)(x + 2)} \\ &= \frac{4 + x^2 + 4x}{4(x + 1)(x + 2)} \\ &= \frac{x^2 + 4x + 4}{4(x + 1)(x + 2)} \\ &= \frac{(x + 2)(x + 2)}{4(x + 1)(x + 2)} \\ &= \frac{x + 2}{4(x + 1)} \cdot \frac{(x + 2)}{(x + 2)} \\ &= \frac{x + 2}{4(x + 1)} \end{aligned}$$



- 14. Higher Order Thinking** Find the slope of the line that passes through the points shown. Express in simplest form.

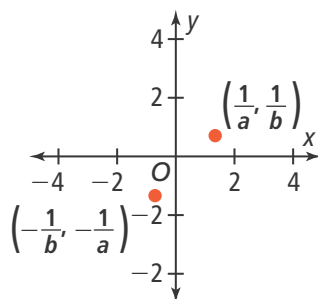

- 15. Reason** For what values of x is the sum of $\frac{x - 5y}{x + y}$ and $\frac{x + 7y}{x + y}$ undefined? Explain.
- 16. Error Analysis** A student says that the LCM of $3x^2 + 7x + 2$ and $9x + 3$ is $(3x^2 + 7x + 2)(9x + 3)$. Describe and correct the error the student made.

PRACTICE

- Find the sum.** SEE EXAMPLE 1
17. $\frac{4x}{x + 7} + \frac{9}{x + 7}$ 18. $\frac{3y - 1}{y^2 + 4y} + \frac{9y + 6}{y(y + 4)}$

- Find the LCM for each group of expressions.**
SEE EXAMPLE 2

19. $x^2 - 7x + 6, x^2 - 5x - 6$
20. $y^2 + 2y - 24, y^2 - 16, 2y$

- Find the sum.** SEE EXAMPLE 3
21. $\frac{6x}{x^2 - 8x} + \frac{4}{2x - 16}$ 22. $\frac{3y}{2y^2 - y} + \frac{2}{2y}$

- Find the difference.** SEE EXAMPLE 4
23. $\frac{4x}{x^2 - 1} - \frac{4}{x - 1}$ 24. $\frac{y - 1}{3y + 15} - \frac{y + 3}{5y + 25}$

25. On Saturday morning, Ahmed decided to take a bike ride from one end of the 15-mile bike trail to the other end of the bike trail and back. His average speed the first half of the ride was 2 mph faster than his speed on the second half. Find an expression for Ahmed's total travel time. If his average speed for the first half of the ride was 12 mph, how long was Ahmed's bike ride? SEE EXAMPLE 5



- Rewrite as a rational expression.** SEE EXAMPLE 6

26. $\frac{1 + \frac{1}{x}}{x - \frac{1}{x}}$ 27. $\frac{\frac{3}{y} + \frac{7}{x}}{\frac{1}{y} - \frac{2}{x}}$
28. $\frac{\frac{1}{a} + \frac{1}{b}}{a^2 - b^2}$ 29. $\frac{\frac{z^2 - z - 12}{z^2 - 2z - 15}}{\frac{z^2 + 8z + 12}{z^2 - 5z - 14}}$

APPLY

30. **Use Structure** Aisha paddles a kayak 5 miles downstream at a rate 3 mph faster than the river's current. She then travels 4 miles back upstream at a rate 1 mph slower than the river's current. Hint: Let x represent the rate of the river current.

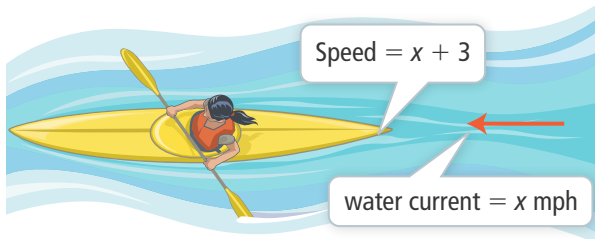

- Write and simplify an expression to represent the total time it takes Aisha to paddle the kayak 5 miles downstream and 4 miles upstream.
 - If the rate of the river current, x , is 2 mph, how long was Aisha's entire kayak trip?
31. **Model With Mathematics** Rectangles A and B are similar. An expression that represents the width of each rectangle is shown. Find the scale factor of rectangle A to rectangle B in simplest form.

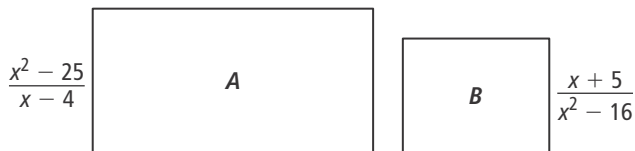

32. **Reason** The Taylor family drives 180 miles (round trip) to a professional basketball game. On the way to the game, their average speed is approximately 8 mph faster than their speed on the return trip home.
- Let x represent their average speed on the way home. Write and simplify an expression to represent the total time it took them to drive to and from the game.
 - If their average speed going to the game was 72 mph, how long did it take them to drive to the game and back?

ASSESSMENT PRACTICE

33. Which of the following compound fractions simplifies to $\frac{x+1}{x-3}$? Select all that apply.

| | |
|--|--------------------------------------|
| (A) $\frac{x^2 + 5x + 4}{x^2 + 2x - 8}$ | (B) $\frac{x^2 - 1}{x^2 - 4}$ |
| (C) $\frac{x^2 + 3x - 10}{x^2 - 4x - 5}$ | (D) $\frac{x^2 + 3x - 10}{x^2 - 25}$ |
| | |
| | |
| | |
| | |
| | |

34. **SAT/ACT** What is the difference between $\frac{x}{9}$ and $\frac{x-y}{6}$?

| | |
|--------------------------|--------------------------|
| (A) $\frac{5x - y}{18}$ | (B) $\frac{5x + y}{18}$ |
| (C) $\frac{-x + 3y}{18}$ | (D) $\frac{-x - 3y}{18}$ |

35. **Performance Task** The lens equation $\frac{1}{f} = \frac{1}{d_i} + \frac{1}{d_o}$ represents the relationship between f , the focal length of a camera lens, d_i , the distance from the lens to the film, and d_o , the distance from the lens to the object.

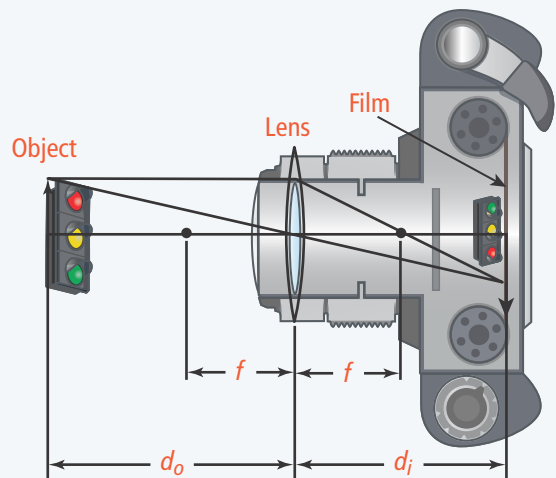

Part A Find the focal length of a camera lens if an object that is 12 cm from a camera lens is in focus on the film when the lens is 6 cm from the film.

Part B Suppose the focal length of another camera lens is 3 inches, and the object to be photographed is 5 feet away. What distance (to the nearest tenth inch) should the lens be from the film?